

REV	DESCRIPTION	DATE	APPROVED
A	PRODUCTION RELEASE PER ECO# 4565	02/16/07	

Mfg. Process: PRINTING
 Ink: BLACK
 Material: 20# MEAD BOND, WHITE
 Binding: NONE
 Finished Size: 4.25" X 5.5"

		FINAL PART AND FINISHED SIZED ARTWORK TOLERANCE: <input type="checkbox"/> ± .040" <input checked="" type="checkbox"/> ± .125" <input type="checkbox"/> ± _____"				12950 Bradley Avenue Sylmar CA 91342-3829 Phone: 818.362.0353 Fax: 818.362.9506	
				TITLE INSTRUCTIONS,CMD,KMD,MMD			
		DRAWN E. Leu	DATE 01/31/07				
		COG. ENGINEER	DATE	SCALE 1-1	SIZE A	DRAWING NO. 08905076	REV. A
		CHECKED	DATE	FILE NAME		SHEET <u>1</u> OF <u>5</u>	

INSTALLATION INSTRUCTIONS

CMD, KMD, MMD Designer Series Keypad Module

DESCRIPTION

Perhaps the easiest way to become familiar with the SmartPad3 is to gain an understanding of the modules that make up the system. The Designer Series modules are divided into two basic grounds: the Key (or button) modules, and the docking Base modules. This instruction sheet provides details on the Key (or button) modules. All Designer Series Key Modules are compatible with the full line of SmartPad3 docking modules including the PM, LM, and EM series.

The Designer Series Key modules provide an updated contemporary style. Available in three different flavors are the MMD (Master Module), KMD (Key Module), and CMD (Cursor Module). Each Key Module comes with the following: White bezel, over 700 plus button labels, clear button caps, main key module assembly.

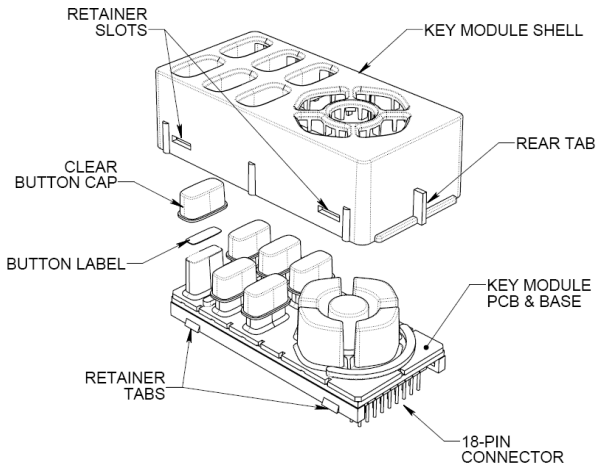

INSTALLATION

1. First, decide on the button labels you need and their locations.
2. Pick up the **Key Module PCB & Base** assembly and carefully place each button label onto the **Rubber Actuators** in the location you desire.
3. When the button labels are completely in place, place the **Clear Button Cap** over the **Button Label** and **Rubber Actuators**.

NOTE: As received from the factory, the **Key Module Shell** is separate from the **Key Module PCB & Base** Assembly.

4. Pick up the **Key Module Shell** and lower it over the **Key Module PCB & Base** assembly.
5. Move the buttons slightly, as necessary, to align them so that they pass through the button openings in the **Key Module Shell**.
6. Carefully press the **Key Module Shell** down until the 4 small Retainer Tabs on the **Key Module PCB & Base** assembly snap into the corresponding **Retainer Slots** in the **Key Module Shell**.
7. Mount the completed Key Module into the PM or LM or EM. Place the front tab of the Key Module under the small lip of the LM, PM or EM. Align the 18-pin connector with the 18-pin socket and carefully push into place.

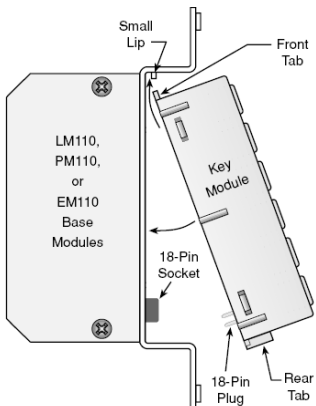

DISASSEMBLY

You may find it necessary, from time to time, to disable the Key Module to change buttons for system updates, etc. Proceed as follows:

1. Remove the Key Module from the PM110 or LM110 or EM110 by pulling upward at the 18-pin connector end of the module.
2. Grasp the Key Module with both hands, with the buttons facing you.
3. With the fingers of each hand, pull outward on the lower edges of the **Key Module Shell**.

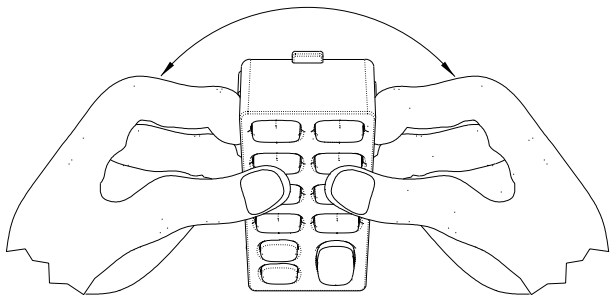

4. As the 4 small retainer tabs recede from the slots on the **Key Modules Shell**, press down on the buttons with your thumbs.
5. The **Key Module Shell** should now move away from the **Key Module PCB & Base** assembly.

CAUTION: To avoid damage, be sure not to use excessive force when executing this disassembly procedure.

6. When you have made the desired button changes, reassemble the unit using the steps given under **INSTALLATION** (section shown above).



xantech

Xantech Corporation
13100 Telfair Avenue, 2/F
Sylmar, CA 91342

Phone: (818) 362-0353, Fax: (818) 362-9506

Instructions, CMD, KMD, MMD © 2007 Xantech Corporation

This document is copyright protected. No part of this manual may be copied or reproduced in any form without prior written consent from Xantech Corporation.

Xantech Corporation shall not be liable for operational, technical, or editorial errors/omissions made in this document.